

BALDOR® • RELIANCE 

Product Information Packet

VPECP4115T

50HP, 1775RPM, 3PH, 60HZ, 326VP, 1272M, TEFC, F

Part Detail							
Revision:	D	Status:	PRD/A	Change #:		Proprietary:	No
Type:	AC	Elec. Spec:	12WGY141	CD Diagram:	CD0180	Mfg Plant:	
Mech. Spec:	12K25	Layout:	12LYK025	Poles:	04	Created Date:	07-14-2015
Base:	N	Eff. Date:	11-04-2019	Leads:	9#6		

Specs			
Catalog Number:	VPECP4115T	Insulation Class:	F
Enclosure:	TEFC	Inverter Code:	Inverter Duty
Frame:	326VP	KVA Code:	H
Frame Material:	Iron	Lifting Lugs:	Vertical Lifting Lugs
Output @ Frequency:	50.000 HP @ 60 HZ	Locked Bearing Indicator:	Locked Bearing
Synchronous Speed @ Frequency:	1800 RPM @ 60 HZ	Motor Lead Quantity/Wire Size:	9 @ 6 AWG
Voltage @ Frequency:	460.0 V @ 60 HZ	Motor Lead Exit:	Ko Box
	230.0 V @ 60 HZ	Motor Lead Termination:	Flying Leads
XP Class and Group:	CLI GP A,B,C,D	Motor Type:	1272M
XP Division:	Division II	Mounting Arrangement:	F1
Agency Approvals:	UR	Power Factor:	85
	CSA EEV	Product Family:	Chemical Processing (Not DC)
	CSA	Pulley End Bearing Type:	Thrust
Auxillary Box:	No Auxillary Box	Pulley Face Code:	P-Base
Auxillary Box Lead Termination:	None	Pulley Shaft Indicator:	P-Base Groove & Key
Base Indicator:	No Mounting	Rodent Screen:	None
Bearing Grease Type:	Polyrex EM (-20F +300F)	Shaft Extension Location:	Pulley End
Blower:	None	Shaft Ground Indicator:	No Shaft Grounding

Constant Torque Speed Range:	.8	Shaft Rotation:	Reversible
Current @ Voltage:	116.000 A @ 230.0 V	Shaft Slinger Indicator:	Shaft Slinger
	58.000 A @ 460.0 V	Speed Code:	Single Speed
Design Code:	A	Motor Standards:	NEMA
Drip Cover:	Drip Cover	Starting Method:	Direct on line
Duty Rating:	CONT	Thermal Device - Bearing:	None
Electrically Isolated Bearing:	Not Electrically Isolated	Thermal Device - Winding:	None
Feedback Device:	NO FEEDBACK	Vibration Sensor Indicator:	No Vibration Sensor
Front Face Code:	Standard	Winding Thermal 1:	None
Front Shaft Indicator:	None	Winding Thermal 2:	None
Heater Indicator:	No Heater	XP Temp Code:	T3

Nameplate NP3241											
CAT.NO.	VPECP4115T	P/N		ENCLOSURE	TEFC						
SPEC.	12K025Y141G1	CC	010A	FRAME	326VP	S/N					
HP	50	CLASS	F	HZ	60	DES	A				
RPM	1775	RPM MAX	2700	PH	3	KVA-CODE	H				
VOLT	230/460	MOTOR WEIGHT	725								
AMP	116/58	SER.F.	1.15	PF	85	ODE BRG	6311	DE BRG	QJ312/7312		
RATING	40C AMB-CONT	NEMA-NOM-EFF	94.5	GREASE	POLYREX EM						
				INV.TYPE	PWM						
TEMP CODE	T3	INVERTER-TEMP-CODE	200								
TEMP =	200	C HP FR	60	C HP TO	90						
CT HZ FROM	.8	CT HZ TO	60								
HTR-VOLTS		HTR-AMPS		HTR-WATTS		MAX. SPACE HEATER TEMP.		VT HZ FROM	0	VT HZ TO	60

Parts List		
Part Number	Description	Quantity
SA303908	SA 12K025Y141G1	1.000 EA
RA291060	RA 12K025Y141G1	1.000 EA
09FN3001C03	EXTERNAL FAN, PLASTIC	1.000 EA
10CB1000A16P	KOBX, MACH 2.00 NPT W/#26 DRAIN W/PRIMER	1.000 EA
09GS1010	GASKET, DWG, LEADWIRE SEPERATOR	1.000 EA
10XN3118K16	5/16-18 X 1' GRADE #5, STL, ZINC PLATE	4.000 EA
HW1001A31	LOCKWASHER 5/16, ZINC PLT.591 OD, .319 I	4.000 EA
WD1000B16	T&B CX70TN OR L70P TERMINAL LUG	1.000 EA
10XN2520K08	1/4-20 X .50 GRADE #5, STL, ZINC PLATE	1.000 EA
HW1001A25	LOCKWASHER 1/4, ZINC PLT .493 OD, .255 I	1.000 EA
HA4051A00	PLASTIC CAP FOR GREASE FITTING	1.000 EA
HW4600B41	V-RING SLINGER 2.125 X 2.880 X 0.280	1.000 EA
HA3400A18	STUD .50-13 X 7.50L W/4.19L HEX WELKER	4.000 EA
HW1001A50	LOCKWASHER 1/2, ZINC PLT.,.879 OD, .509 I	4.000 EA
HW4600B41	V-RING SLINGER 2.125 X 2.880 X 0.280	1.000 EA
HW5100A13	W4627-047 WVY WSHER	1.000 EA
10XN3118K36	5/16-18 X 2.25" HEX HD, GRADE 5	2.000 EA
10XN3118K72	5/16-18 X 4.50" HEX HD, GRADE 5	4.000 EA
12EP1502A03P	PULLEY ENDPLATE, MACH. W/EPOXY PRIMER	1.000 EA
HA4051A00	PLASTIC CAP FOR GREASE FITTING	1.000 EA
10XN5013K40	1/2-13X 2 1/2 HEX HD X	4.000 EA
HW1001A50	LOCKWASHER 1/2, ZINC PLT.,.879 OD, .509 I	4.000 EA
12FH1002A08P	FAN COVER, MACH W/EPOXY PRIMER	1.000 EA
HW1001A50	LOCKWASHER 1/2, ZINC PLT.,.879 OD, .509 I	4.000 EA

Parts List (continued)		
Part Number	Description	Quantity
XY5013A12	NUT,1/2-13,HEX,STEEL,ZINCPLATED	4.000 EA
HW3203A02	1/2-13 HVY FORGED EYE-NUT	2.000 EA
12FH1500A01P	MACH DRIP COVER 310-312 MTRS	1.000 EA
10XN3816K36	3/8-16 X 2.25 HEX HD CAP SCREW, GRADE 5	4.000 EA
HW1001A38	LOCKWASHER 3/8, ZINC PLT .688 OD, .382 I	4.000 EA
10CB1503A01P	CONDUIT BOX LIPPED LID, MACH W/EPXY PRMR	1.000 EA
14GS1003	GASKET CONDUIT BOX LID, NEOP	1.000 EA
10XN2520K16	1/4-20 X 1" HX HD SCRW GRADE 5, ZINC P	4.000 EA
HW1001A25	LOCKWASHER 1/4, ZINC PLT .493 OD, .255 I	4.000 EA
HW2501G32	KEY, 3/8 SQ X 3.750	1.000 EA
MJ5001A27	32220KN GRAY SEALER *MIN BUY 4 QTS=1GAL	0.031 QT
MJ5001A14	DYNAPRO SEALANT, CP MTR VC#2508050 (603	0.029 EA
LB1115N	LABEL,LIFTING DEVICE (ON ROLLS)	1.000 EA
LB1182	WARNING LABEL FOR MOTORS WITH EYENUTS	2.000 EA
LB1002N	LABEL,MARINE DUTY (ON ROLLS)	1.000 EA
PK6014	STEEL STRAP FOR 309-312 BASELESS MOTORS	3.000 EA
10XN5013K10	1/2-13 X .625 HEX HD, GRADE 5	3.000 EA
12EP1107A14GP6	FREP, MACH W/EPOXY PRIMER & MG1025N19	1.000 EA
HW4500A17	317400 ALEMITE GREASE RELIEF	1.000 EA
HA4017A03	.125 X 1.75 GREASE EXT (F/S)	1.000 EA
HW4019A01	PIPE COUPLING 1/8 NPT,STEEL,ZINC COATING	1.000 EA
HW4500A21	1618BALEMITE FITTING 825 UNIVERSAL	1.000 EA
HA4017A01	1/8 X 4 GREASE EXT (F/S)	1.000 EA
MJ1000A02	GREASE, MOBIL POLYREX EM - 124047	0.200 LB

Product Information Packet: VPECP4115T - 50HP,1775RPM,3PH,60HZ,326VP,1272M,TEFC,F

HW4500A17	317400 ALEMITE GREASE RELIEF	1.000 EA
HW4500A03	GREASE FITTING, .125 NPT 1610(ALEMITE) 8	1.000 EA
HA4054	SHORT T-DRAIN FITTING, .125" N.P.T.	1.000 EA
HW2500A25	WOODRUFF KEY USA #1008 #BLOW CARBON STEE	1.000 EA
51XB1214A20	12-14X1.25 HXWSSLD SERTYB	1.000 EA
MG1025N19	WILKOFASST, 778.50, RELIANCE BLUE-GREEN	0.080 GA
85XU0407S04	4X1/4 U DRIVE PIN STAINLESS	4.000 EA
LB1119N	WARNING LABEL	1.000 EA
LB1449	DIV-2/NEC WARNING LABEL	1.000 EA
LC0181	CONNECTION LABEL	1.000 EA
NP3241	SS SUPER-E INV UL CSA-EEV PREM CC	1.000 EA
18PA1080	PKG. GRP 312 VERT 14.75BC 4.9SH 40X30X30	1.000 EA
MN416A01	TAG-INSTAL-MAINT no wire (1200/bx) 3/19	1.000 EA

AC Induction Motor Performance Data

Record # 47180 - Typical performance - not guaranteed values

Winding: 12WGY141-R031	Type: 1272M	Enclosure: TEFC
-------------------------------	--------------------	------------------------

Nameplate Data				460 V, 60 Hz: High Voltage Connection	
Rated Output (HP)	50			Full Load Torque	147 LB-FT
Volts	230/460			Start Configuration	direct on line
Full Load Amps	116/58			Breakdown Torque	396 LB-FT
R.P.M.	1775			Pull-up Torque	183 LB-FT
Hz	60	Phase	3	Locked-rotor Torque	254 LB-FT
NEMA Design Code	A	KVA Code	H	Starting Current	397 A
Service Factor (S.F.)	1.15			No-load Current	19.8 A
NEMA Nom. Eff.	94.5	Power Factor	85	Line-line Res. @ 25°C	0.10889 Ω
Rating - Duty	40C AMB-CONT			Temp. Rise @ Rated Load	64°C
S.F. Amps				Temp. Rise @ S.F. Load	79°C

Load Characteristics 460 V, 60 Hz, 50 HP

% of Rated Load	25	50	75	100	125	150	S.F.
Power Factor	53	74	83	86	87	87	87
Efficiency	91.3	94.3	94.8	94.6	94	93.1	94.2
Speed	1794.5	1789.3	1783.5	1777.5	1770.7	1761.5	1773
Line amperes	24.2	33.5	44.7	57.6	71.5	90	65.9

Performance Graph at 460V, 60Hz, 50.0HP Typical performance - Not guaranteed values

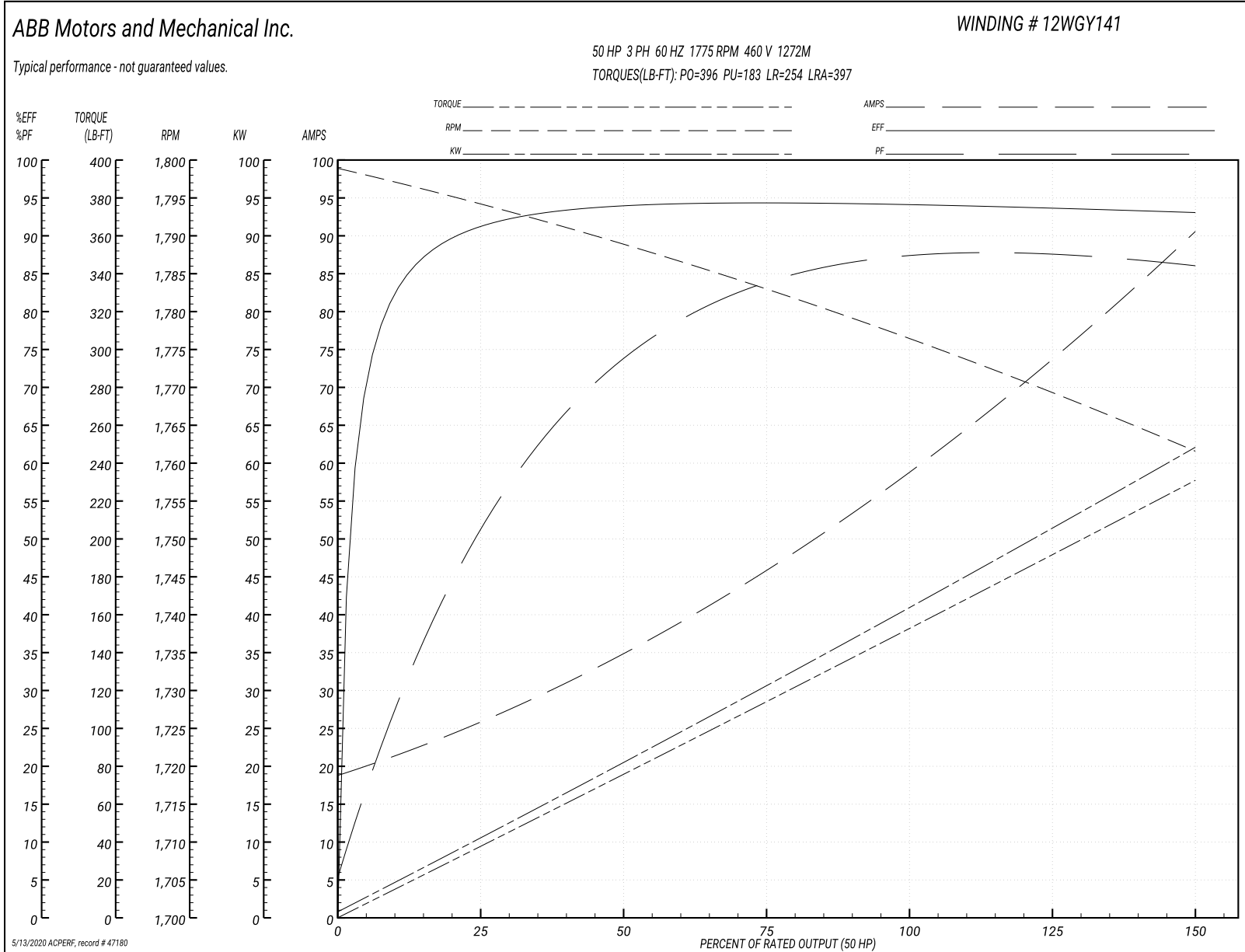

12LYK025

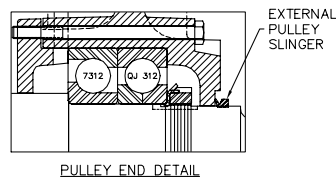
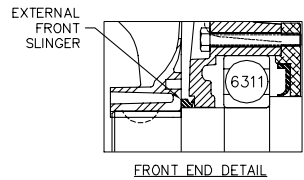
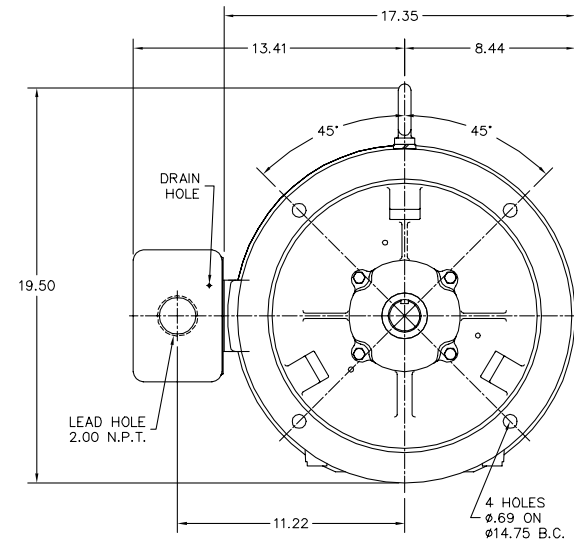
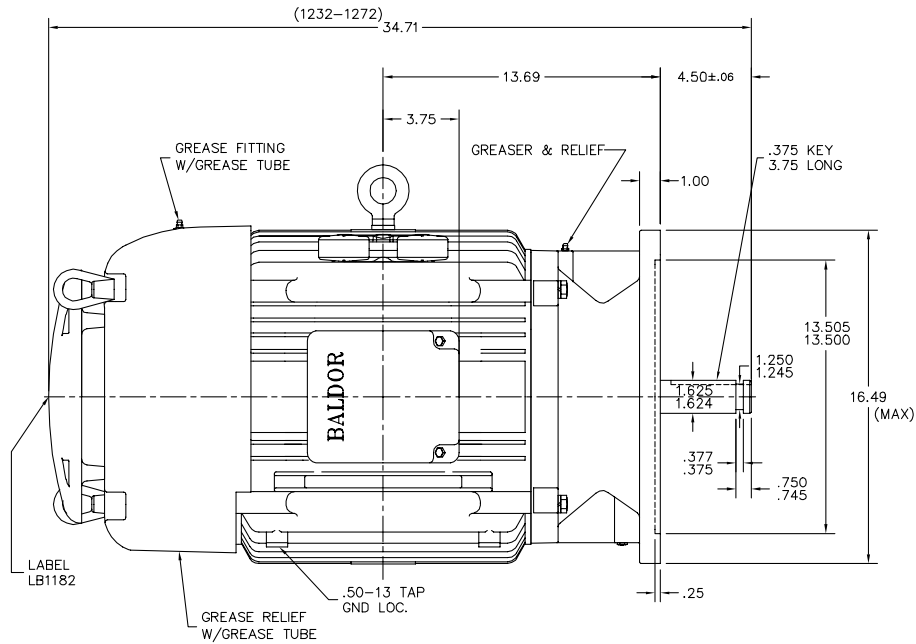

CUSTOMER IS RESPONSIBLE FOR DETERMINING THAT BALDOR'S PRODUCT WILL PERFORM SUITABLY IN THE INTENDED APPLICATION.

REV. DESC: CHG DESCRIPTION & ADDED GND HOLE TAP SIZE		
REV. LTR: L	VERSION: 08	TDR: 00000951550
FILE: \AAA\00011\609	REVISED: 11:02:10 12/07/2015	BY: ENNINDO
MTL: -		

BALDOR

VERT TEFC 324-6VP CP W/312 THRUST PAC
SH 1 of 1

12LYK025

CD0180



LOW VOLTAGE
(2D)



HIGH VOLTAGE
(1D)



NOTES:

1. INTERCHANGE ANY TWO LINE LEADS TO REVERSE ROTATION.
2. OPTIONAL THERMOSTATS ARE PROVIDED WHEN SPECIFIED.
3. ACTUAL NUMBER OF INTERNAL PARALLEL CIRCUITS MAY BE A MULTIPLE OF THOSE SHOWN ABOVE.
4. LEAD COLORS ARE OPTIONAL. LEADS MUST ALWAYS BE NUMBERED AS SHOWN.

CD0180

REV. DESC: ADD CLASS CONN00000007		
REV. LTR: D	VERSION: 01	TDR: 000001099922
FILE: \AAA\00005\148	REVISED: 10:25:29 02/19/2019	BY: ENBRIRO
MTL: -	© □	

BALDOR - RELIANCE®

3PH, DV, 9 LEADS, DELTA CONNECTION

SH 1 of 1

Marketing maintained PDF of MN416:

<http://www.baldor.com/support/Literature/Load.ashx/MN416?ManNumber=MN416>